

► Our technology. Your success.

Pumps · Valves · Service



AmaDrainer® 3 – Submersible Motor Pump

Applications:

- Drainage of pits, shafts, yards and cellars subject to a flooding risk
- Water extraction from reservoirs and rivers
- Emergency drainage
- Drainage of outside basement stairwells and underground passages
- Lowering of surface water levels
- Drainage



AmaDrainer® 301



AmaDrainer® 303



AmaDrainer® 322



AmaDrainer® 354

AmaDrainer® 3 – Submersible Motor Pump

Flexible

- Integrated low water level intake (sizes 301, 303)
- Use with or without control unit
- All sizes available in material variant for aggressive fluids.
- Versions with large free passage also suitable for fluids containing larger solids (e.g. from washing machines):
 - size 322: 18 mm
 - size 354: 35 mm

High operating reliability and dependability

- Integrated swing check valve (sizes 301, 303, 322)
- Integrated motor protection
- Jacket-cooled motor permits operation even when motor is not submerged.
- Long service life with high-quality plastic casing; low-weight and corrosion-proof

Space-saving

- Compact dimensions for space-saving installation
- Integrated float switch

Fast and convenient commissioning

- Easy installation, ready-to-connect

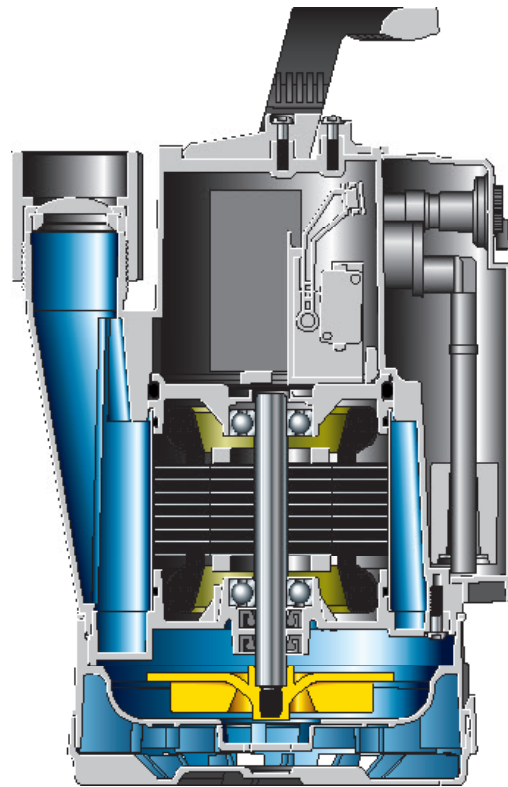

Technical data

Flow rate	Up to 12 m ³ /h (3.4 l/s)
Head	Up to 11.3 m
Fluid temperature	Up to +70 °C (short period up to 90 °C)
Free passage	Up to 35 mm
Cable length	10 m
Voltage	230 V

Optional automation with Level Control Basic 2 control unit

AmaDrainer® 3 characteristic curves

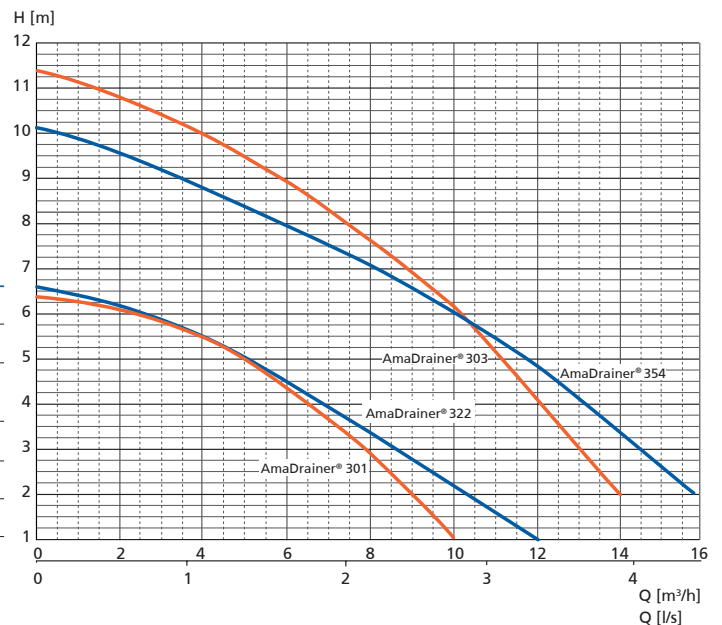

2332.021-EN / 03.21 Subject to technical modification without prior notice.



KSB Limited
Standard Pumps Division
 Plot No. E-3 & E-4, MIDC Sinnar, Nashik - 422 113.
 Tel.: +91-2551-230252 / 53, 229700 www.ksbindia.co.in

Our toll free no : 1800 233 1299
 (Mon-Sun. 8 am to 8 pm)

Mktg. Services / 01-22 / 1000